

ADJUSTABLE MINI WALL PACK

L15/25-MWP-30/50-120/277-PC

OVERVIEW

Simply Conserve's field-adjustable mini wall pack includes dip switches on the unit, allowing for adjustment of the input power and color temperature. There is also a dip switch to toggle photocell functionality on or off. This mini wall pack's durable construction allows for easy installation in a variety of applications for new construction, remodel, and retrofit projects.

CATALOG #		TYPE
PROJECT		
COMMENTS		DATE
PREPARED BY		

KEY FEATURES

- Field-adjustable lumen and CCT
- Built-in photocell, with toggle to bypass
- Wet-location, IP65-rated
- Architectural bronze finish, anti-corrosion spray
- Durable UV-stabilized PC lens
- L70-rated lifetime of 50,000 hours



WET-RATED



INTEGRATED PHOTOCELL



EASY TO INSTALL



FIELD ADJUSTABLE



SOURCE	WATTAGE	FIXTURE TYPE	CCT	VOLTAGE	OPTIONS
L = LED	15/25 = 15W, 20W, 25W	MWP = Mini Wall Pack	30/50 = 3000K, 4000K, 5000K	120/277 = 120-277V	PC = Photocell

SPECIFICATIONS

CATALOG #	WATTS	CCT	LUMENS	EFFICACY	CRI	VOLUME	DIM
L15/25-MWP-30/50-120/277-PC	15/20/25W	3000/4000/5000K	1800/2400/3000	120 LPW	≥80	120-277V	0-10V

DIMENSIONS

PRODUCT

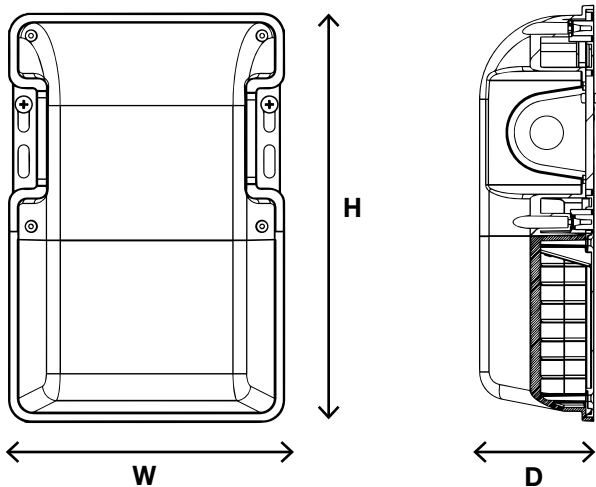

CASE

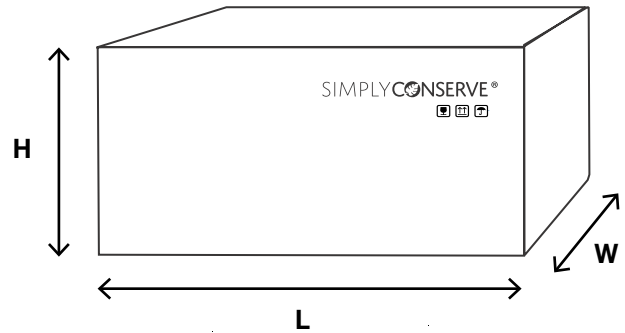

CATALOG #	L	W	D
L15/25-MWP-30/50-120/277-PC	8.8"	5.9"	2.5"

CATALOG #	L	W	H	CASE QTY.	GROSS WT.
L15/25-MWP-30/50-120/277-PC	19"	14"	10"	12	21.6 lbs

5-Year Limited Warranty



AM Conservation® guarantees to the original purchaser or recipient of a wall pack that it is free from defects in material and workmanship for a period of 5 years. AM Conservation will at our choice replace any part of the wall pack which is in our opinion defective provided that the product has not been abused, misused, altered, or damaged after its purchase. This includes damage due to the use of tools or harsh chemicals. In the event a product has been discontinued, AM Conservation will replace it with what we determine to be the closest product. AM Conservation is not responsible for labor charges, installation, or other consequential cost. AM Conservation's responsibility shall not exceed the original cost of the product.

For warranty claims, please contact:

customer@amconservation.com

To learn more, please visit:

www.amconservation.com